

FEATURES AND SPECIFICATIONS

Features and Benefits

- Dual opposing beam contact
- Board lock option
- Flux-proof option
- Solder tails for 1.6mm (.062") and 2.4mm (.094") PCBs available

Reference Information

Product Specification: PS-85052-0001

Packaging: Box

UL File No.: E29179

CSA File No.: LR19980-390

Mates With:

[85001](#)—Right angle male style B/2

[85011](#)—Straight male style Q/2

Electrical

Electrical Current: 1.5A

Contact Resistance: 20mΩ max.

Mechanical

Mating Force: 0.93N max.

Physical

Housing: Glass-filled polyester, UL 94V-0

Contact: Copper Alloy

Operating Temperature: -55 to +125°C



2.54mm (.100") Pitch DIN 41612/IEC 603-2 Connector

85050

Female Style Q/2

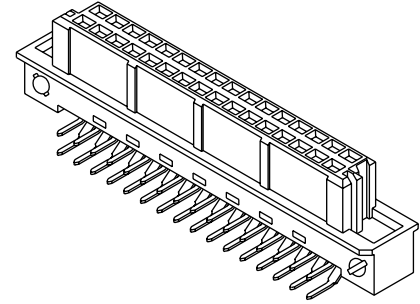

CATALOG DRAWING (FOR REFERENCE ONLY)

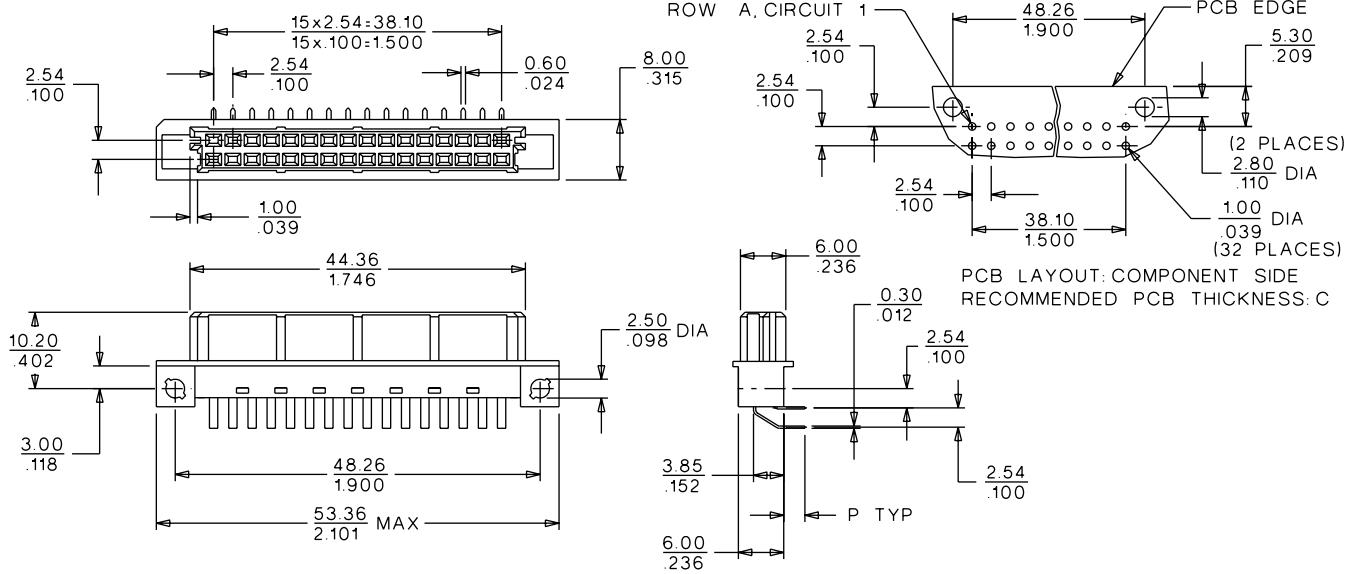

ORDERING INFORMATION AND DIMENSIONS

Circuits	Order No.		Contact Loading	Rows	Solder Tail Dimension P	Option(s)
	Performance Level*					
	1	2				
32	85050-0098	85050-0000 85050-0074	Full	a, b	3.0 (.118)	Board locks

For other versions contact Molex

* Performance levels based on test conditions per DIN 41612, part 5:

1: >500 mating cycles. 10 day industrial environment (S02)

2: >400 mating cycles. 4 day industrial environment (S02)

Backplane Connector Systems

