



Motor Start

Capacitors

ALUMINIUM ELECTROLYTIC CAPACITORS

MS / MD Motor Starting Capacitors

DIMENSIONS mm

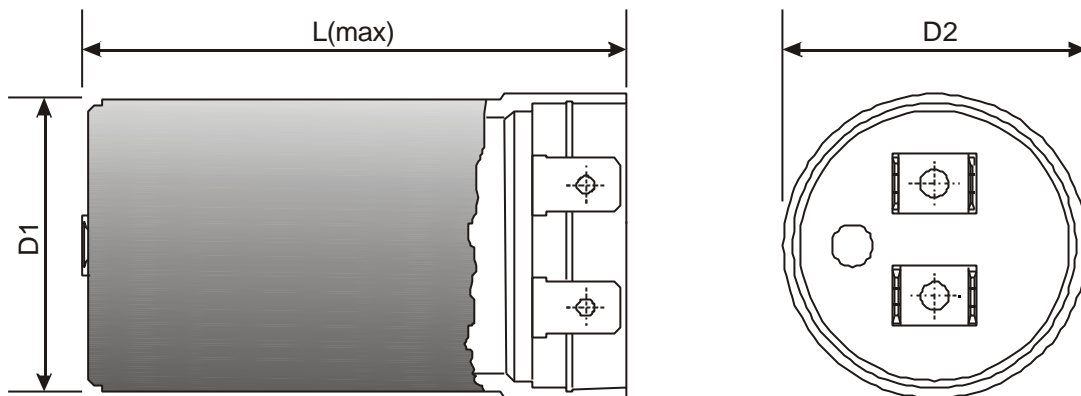

Case Code	D1 ±0.5 (mm)	D2 ±0.5 (mm)	Lmax (mm)
AA	38	39	75
AB	38	39	90
AC	38	39	116

ACCESSORIES

The following accessories are also available,
Leads, Discharge resistors, End Caps, Clamps.

BHC Components Ltd.

20-21 Cumberland Drive, Granby Industrial Estate, Weymouth, Dorset, DT4 9TE. United Kingdom
Tel: +44 1305 782871 Fax: +44 1305 760670 Website: <http://www.bhc.co.uk> Email: bhcsales@bhc.co.uk

MS / MD Motor Starting Capacitors

TECHNICAL DATA

Capacitance

Motor start capacitors are tested as recommended in BS5267 - 'Capacitance shall be determined by measuring the current through the capacitor at the rated voltage and frequency of the capacitor.'

The current should be read within 3 seconds after energising.'

$$\text{Capacitance } \mu\text{F at 50Hz} = \frac{3180 \times I}{V}$$

Where: I=current in amperes and V=applied voltage in volts

Voltage Rating (a.c.)

Due to the presence of the auxiliary start winding, the voltage appearing on the motor start capacitor is usually higher than that of the motor or line voltage. The voltage generally rises with the speed of the motor and varies with the motor load during start-up. Unloaded conditions can give voltages of 15% more than that of loaded.

It is essential that the capacitor is disconnected before the voltage exceeds its maximum voltage rating.

Rated Voltage (rms)	Maximum Cut-Off Voltage (rms)
120	150
220	275
260	325
280	350
330	413

Dual Voltage Rating

The MD range of BHC Components capacitors is designed with a dual voltage rating. The lower voltage rating relates to a duty cycle of 1.67% and the upper voltage rating relates to a duty cycle of 0.55%.

Power Factor

The tangent of the loss angle for motor start capacitors shall not exceed 0.1 and shall be calculated as follows:

$$\text{Tan } \delta = \frac{W}{V \times I} = \frac{\text{true watts}}{\text{apparent watts}}$$

BHC Components Ltd.

20-21 Cumberland Drive, Granby Industrial Estate, Weymouth, Dorset, DT4 9TE. United Kingdom
Tel: +44 1305 782871 Fax: +44 1305 760670 Website: <http://www.bhc.co.uk> Email: bhcsales@bhc.co.uk

MS / MD Motor Starting Capacitors

Duty Cycle

The standard rating is 1.67% or 1/60th full time and corresponds to a maximum duty of 20 starts, each of three seconds duration per hour. It is expressed following BS5267: 1967 and IEC 252 1975, as 3/1.67 (a 3 minute cycle with 1.67% duration during which the capacitor may be energised). If the same capacitor is to be used for a duty cycle of 60 starts per hour the cycle duration will be 1 minute. The operation time per cycle will then have to be reduced to 1.67% of 1 minute (i.e. 1 second). Alternative duty cycles are available on request. Most popular are 0.55% and 1%.

Presence of a Run Capacitor

When the motor is fitted with both starting and run capacitors, consideration should be given to fitting of the appropriate discharge resistor to the starting capacitor. This is to protect the run capacitor from damage through discharge of the starting capacitor.

Container Form

Cylindrical mouldings, meeting creepage and clearance distances, according to IEC 335-1 and flammability ratings according to UL94-V1.

Discharge Resistors

A discharge resistor may be fitted to a motor start capacitor to prevent electrical overstress of the capacitor and or for safety reasons. In accordance with BS5267 and IEC252, the resistor value should be such that it reduces the voltage on the capacitor, from the line voltage to less than 50V within 60 secs.

The resistor value may be approximated as follows:

$$R \text{ (k}\Omega\text{) max.} = \frac{T}{\text{Rated capacitance } \mu\text{F}}$$

Rated Voltage (dc)	T
120	50000
220	32000
260	30000
280	28000
330	26000

Standard Resistor Values

Value (Ohms)	Wattage
5.6K	2W
15K	2W
33K	0.5W
56K	1W
82K	2W
100K	1W

BHC Components Ltd.

20-21 Cumberland Drive, Granby Industrial Estate, Weymouth, Dorset, DT4 9TE. United Kingdom
Tel: +44 1305 782871 Fax: +44 1305 760670 Website: <http://www.bhc.co.uk> Email: bhcsales@bhc.co.uk

MS / MD Motor Starting Capacitors

Shelf Life

Capacitors may be stored for periods up to 2 years without detriment, but after long periods it is a safeguard to test them before putting them into service. In service, the oxide film, which is the dielectric of the capacitor, is maintained in good condition because any imperfections permit a current to pass and the resulting electrolysis forms a new oxide layer. Deterioration of the film takes place if the capacitor is stored for long periods and it is preferable for the 'reforming' of the film to be brought about before the capacitor is subject to its full duty. If a motor start capacitor is already connected to the motor, the reforming can be achieved by freeing the motor from its load and switching on several times.

Part Numbering:

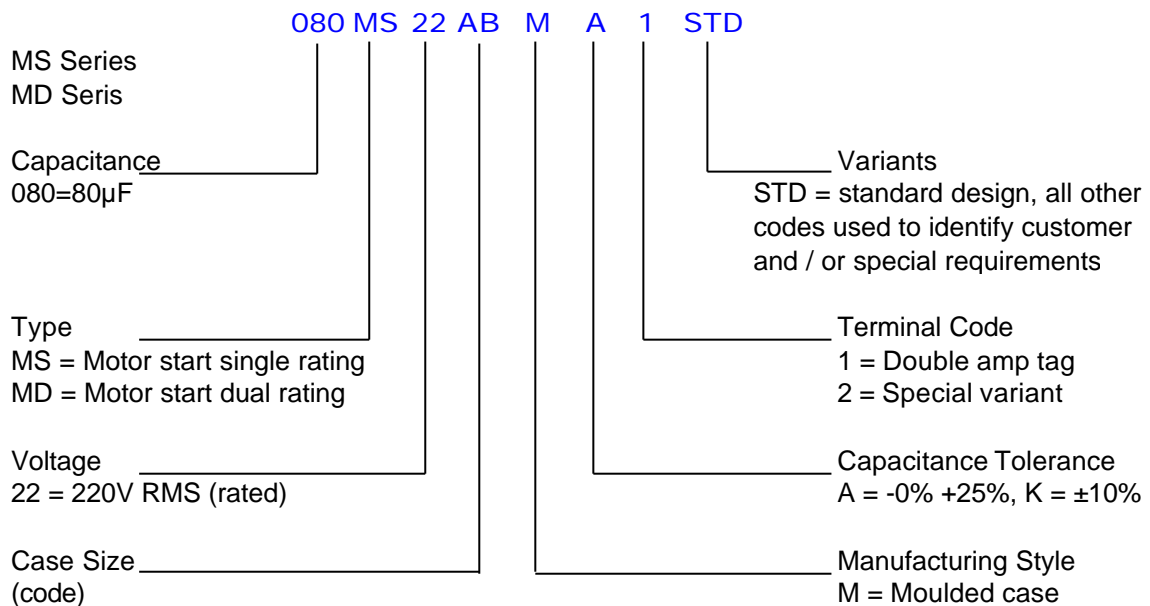

Capacitor Marking

The capacitors are marked with all the items from the following list as a minimum.

1. Rated capacitance in μ F
2. Rated voltage a.c.
3. Duty cycle
4. Frequency
5. Temperature range
6. Date code
7. BHC Components part number
8. Climatic category
9. Approvals

BHC Components Ltd.

20-21 Cumberland Drive, Granby Industrial Estate, Weymouth, Dorset, DT4 9TE. United Kingdom
Tel: +44 1305 782871 Fax: +44 1305 760670 Website: <http://www.bhc.co.uk> Email: bhcsales@bhc.co.uk

MS / MD Motor Starting Capacitors

Capacitance Ranges

Series	MIN CAP (μ F)	MAX CAP (μ F)	Tolerance	Can Size (mm)	Duty Cycle	
					@ 120V rms (Surge Voltage=150V)	@ 150V rms (Surge Voltage=188V)
MS12AAMA1STD	25	325	-0% +25%	38x75	1.67%	
MS12AAMK1STD	25	360	\pm 10%	38x75	1.67%	
MS12ABMA1STD	85	460	-0% +25%	38x90	1.67%	
MS12ABMK1STD	90	510	\pm 10%	38x90	1.67%	
MS12ACMA1STD	120	670	-0% +25%	38x116	1.67%	
MS12ACMK1STD	130	750	\pm 10%	38x116	1.67%	
MD12AAMA1STD	25	325	-0% +25%	38x75	1.67%	0.55%
MD12AAMK1STD	25	360	\pm 10%	38x75	1.67%	0.55%
MD12ABMA1STD	85	460	-0% +25%	38x90	1.67%	0.55%
MD12ABMK1STD	90	510	\pm 10%	38x90	1.67%	0.55%
MD12ACMA1STD	120	670	-0% +25%	38x116	1.67%	0.55%
MD12ACMK1STD	130	750	\pm 10%	38x116	1.67%	0.55%

Series	MIN CAP (μ F)	MAX CAP (μ F)	Tolerance	Can Size (mm)	Duty Cycle	
					@ 220V rms (Surge Voltage=275V)	@ 280V rms (Surge Voltage=350V)
MS22AAMA1STD	30	65	-0% +25%	38x75	1.67%	
MS22AAMK1STD	30	70	\pm 10%	38x75	1.67%	
MS22ABMA1STD	40	90	-0% +25%	38x90	1.67%	
MS22ABMK1STD	40	100	\pm 10%	38x90	1.67%	
MS22ACMA1STD	55	130	-0% +25%	38x116	1.67%	
MS22ACMK1STD	65	150	\pm 10%	38x116	1.67%	
MD22AAMA1STD	30	65	-0% +25%	38x75	1.67%	0.55%
MD22AAMK1STD	30	70	\pm 10%	38x75	1.67%	0.55%
MD22ABMA1STD	40	90	-0% +25%	38x90	1.67%	0.55%
MD22ABMK1STD	40	100	\pm 10%	38x90	1.67%	0.55%
MD22ACMA1STD	55	130	-0% +25%	38x116	1.67%	0.55%
MD22ACMK1STD	65	150	\pm 10%	38x116	1.67%	0.55%

Series	MIN CAP (μ F)	MAX CAP (μ F)	Tolerance	Can Size (mm)	Duty Cycle	
					@ 260V rms (Surge Voltage=325V)	@ 330V rms (Surge Voltage=413V)
MS26AAMA1STD	25	55	-0% +25%	38x75	1.67%	
MS26AAMK1STD	25	60	\pm 10%	38x75	1.67%	
MS26ABMA1STD	35	75	-0% +25%	38x90	1.67%	
MS26ABMK1STD	35	85	\pm 10%	38x90	1.67%	
MS26ACMA1STD	50	110	-0% +25%	38x116	1.67%	
MS26ACMK1STD	55	125	\pm 10%	38x116	1.67%	
MD26AAMA1STD	25	50	-0% +25%	38x75	1.67%	0.55%
MD26AAMK1STD	25	55	\pm 10%	38x75	1.67%	0.55%
MD26ABMA1STD	30	70	-0% +25%	38x90	1.67%	0.55%
MD26ABMK1STD	35	80	\pm 10%	38x90	1.67%	0.55%
MD26ACMA1STD	45	100	-0% +25%	38x116	1.67%	0.55%
MD26ACMK1STD	50	115	\pm 10%	38x116	1.67%	0.55%

BHC Components Ltd.

20-21 Cumberland Drive, Granby Industrial Estate, Weymouth, Dorset, DT4 9TE. United Kingdom

Tel: +44 1305 782871 Fax: +44 1305 760670 Website: <http://www.bhc.co.uk> Email: bhcsales@bhc.co.uk

MS / MD Motor Starting Capacitors

Approval Status

RATED VOLTAGE→	120	220V		260V	
	VDE	VDE	VDE	VDE	VDE
APPROVAL→					
CAPACITOR TYPE→	MS	MS	MD	MS	MD
CAPACITANCE (uF)					
25	AA			AA	
30	AA	AA		AA	
35	AA			AA	
40	AA	AA,AB	AB	AA,AB	AB
50	AA	AA,AB	AB	AA,AB	AB
60	AA	AA,AB	AB	AA,AB	AB
70		AB	AB	AB,AC	AB
80	AA	AB	AB	AB,AC	AB
90				AB,AC	
100	AA	AC		AB,AC	
120	AA				
125	AA	AC		AC	
150	AA				
160	AA				
180	AB				
200	AB				
230	AB				
250	AB				
300	AB				
310	AC				
315	AC				
350	AC				
400	AC				

The table above shows the capacitor values that have been approved within the can sizes shown. Other unapproved capacitor values are available upon request.

BHC Components Ltd.

20-21 Cumberland Drive, Granby Industrial Estate, Weymouth, Dorset, DT4 9TE. United Kingdom
 Tel: +44 1305 782871 Fax: +44 1305 760670 Website: <http://www.bhc.co.uk> Email: bhcsales@bhc.co.uk



Iss1: 01\08\02